

TF

CUTTER HEADS

PATENT
SIMEX

Double drum cutter heads.



■ Simex TF cutter heads are ideal for trenching, profiling and resurfacing rock and cement walls, tunneling, quarrying, demolitions, dredging and finishing operations.

■ **They are highly effective** where conventional excavation systems are too weak and percussion systems have little effect.

■ **Their quiet operation** allows them to be put to work in sensitive or populated areas (near schools, hospitals, bridges and infrastructure).

■ They are especially effective for finishing operations requiring **maximum precision, minimum intrusion** and an optimum aesthetic result.

ADVANTAGES FOR YOUR BUSINESS





- Precision cutting
- Low vibrations
- High performance
- Low noise output
- Narrow, deep trenching
- Underwater works
- Maintenance-free
- Milled material usable on site



■ FIELDS OF APPLICATION.

- Trenching
- Tunneling
- Stripping and reclamation
- Underwater works
- Quarrying
- Demolition
- Wall profiling



Soft Soil	Medium Soil	Hard Soil Fractured Rock	Very Hard Soil Compact Rocks
BUCKET 			
	RIPPER 		
	SIMEX CUTTER HEAD 		
		BREAKER 	
		EXPLOSIVES 	



■ **High torque and high performance** guaranteed by integrated high displacement hydraulic piston motor. Shaft transmits motion only and bears no load thanks to double support bearings for each drum.

**PATENT
SIMEX**

■ **Milled material is discharged from the trench without getting stuck in the frame** due to special shape, which also allows hoses to be hooked up at sides and front.

■ **Easy mounting on excavators**, which require a high oil flow at low pressure to deliver efficient hydraulic power. Oil flow limiting valve avoids risk of hydraulic motor over revving.

■ **Replaceable anti-wear plates.**

■ **Cutter head can be rotated 90°** thanks to square holes of coupling plate.

■ **Filter on feed line prevents impurities from entering the motor**, for example when hoses are being connected to the excavator.

■ **Gaskets fitted on drums seal against dust** also when attachment is submerged into the ground, even in muddy conditions.

■ **Shaft transmits motion only and bears no load** thanks to double support bearings for each drum.



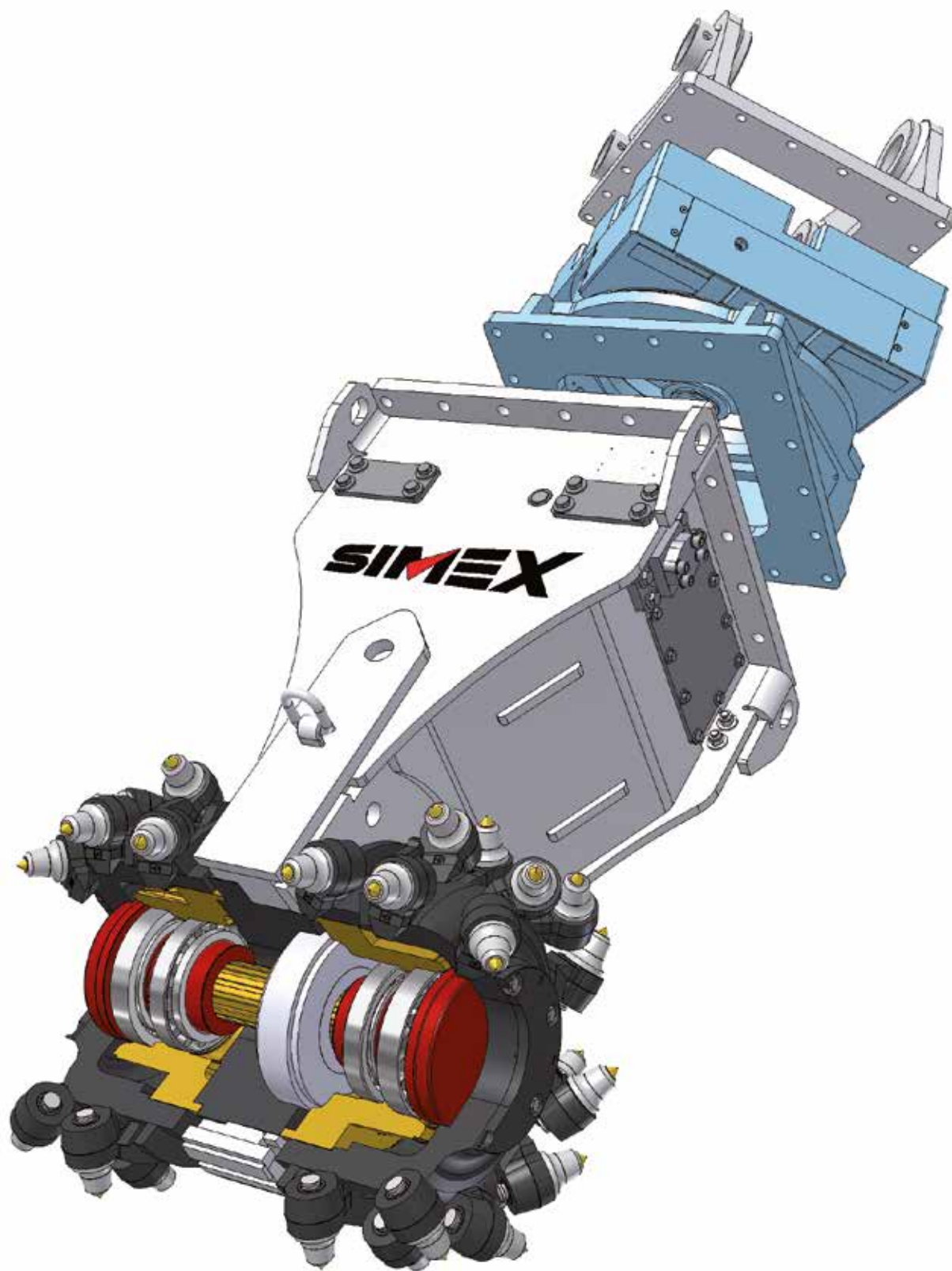



Quarrying



Trenching



Wall profiling



Stripping and reclamation



Tunneling



Underwater works



Cuts for rib installation

360° Hydraulic Rotation (optional)

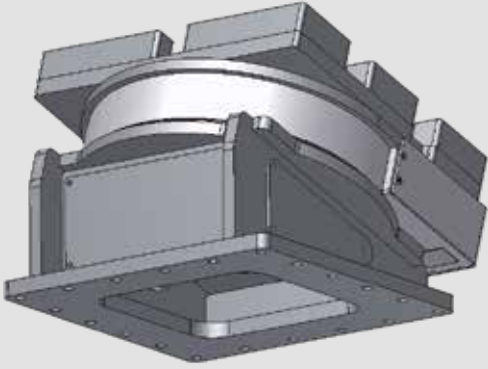

- Hydraulic rotation allows operator to find the ideal working position.
- Increased productivity.
- Maximum precision.

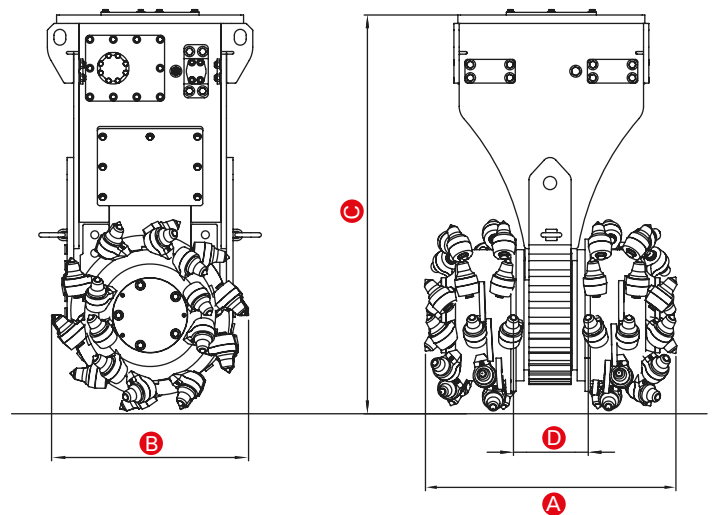

Drums and teeth for any application.

■ Designed to achieve higher efficiency of the demanded application.



HP Drum (standard)

Thanks to special layout of teeth and reduced width, penetrates deep even into hard materials.



GP Drum (optional)

Larger width drum recommended for wall profiling and various types of jobs.



WP Drum (optional)

Special drum for finishing and profiling.

■ Multiple tooth geometries available for milling different materials.



Standard tooth for mixed materials



Tooth for milling very hard materials



Tooth for wood

TECHNICAL SPECIFICATIONS

	TF 200	TF 400	TF 600	TF 850	TF 1100	TF 2100	TF 2500	TF 3100	
Recommended excavator weight	2.5 - 7	6 - 12	9 - 16	14 - 22	20 - 34	28 - 45	40 - 55	50 - 70	ton
Standard drum width (HP) A	565	625	700	800	850	950	1000	1250	mm
Drum width (GP) - optional A	-	-	-	900	1000	1100	1150	1350	mm
Drum width (WP) - optional A	650	750	850	1000	1200	-	-	-	mm
Weight without bracket (1)	300	470	640	1140	1465	2410	2700	3650	kg
Hydraulic motor power	27 (37)	37 (50)	50 (68)	61 (83)	87 (118)	112 (152)	140 (190)	175 (238)	kW (hp)
Torque	2.5	4.6	6.9	10.6	17.5	22.7	31.7	42.5	kNm
Cutting force	13.5	20.3	27.6	35.2	53.4	64.3	83.7	114.5	kN
Max. pressure (2)	350	350	350	350	350	380	380	380	BAR
Required oil flow (3)	45 - 80	65 - 120	90 - 150	130 - 190	170 - 250	240 - 340	280 - 400	350 - 500	l/min
Drum diameter - HP B	380	450	500	595	660	750	750	750	mm
Height without bracket C	770	900	960	1250	1310	1575	1675	1770	mm
Drum distance D	110	130	130	150	160	175	250	300	mm
Tooth holder diameter	20	22	22	38/30	38/30	38/30	38/30	38/30	mm

(1) User is responsible for ensuring that the equipment meets the excavator's specifications and weight requirements.

(2) Torque and cutting force decrease with lowered operating pressure.

(3) RPM and cutting speed decrease with lowered oil flow.